

SP Non-clogging Self-priming Sewage Pump Operation Manual



Hangzhou Nanfang Special Pump Industry Co.,Ltd
Add:Renhe Town Yuhang District, Hangzhou, zhejiang
Tel:+86-571-86397810; +86-571-86397838
Fax:+86-571-86397809
P.C:311107
E-mail:info@nanfang-pump.com
Http://www.nanfang-pump.com

E081101

TABLE OF CONTENTS

I. INTRODUCTION	1
II. STRUCTURE CHARACTERISTIC	3
III. PERFORMANCE CURVE, PERFORMANCE PARAMTER, OPERATION RANGE	4
IV. OUTLINE DRAWING	10
V. INSTALLATION	12
VI. START-UP	18
VII. MAINTENANCE	22
VIII. PUMP SERVICE, DISASSEMBLY AND REASSEMBLY	23
IX. TROUBLESHOOTING	28
X.IMPORTANT NOTICE	30

Read this manual carefully before install, start the pump.
Standard:Q/HNB*** (Non-clogging Self-priming Sewage Pump)

I、 INTRODUCTION

Thank You for purchasing CNP pump. **Read this manual** carefully to learn how to safely install and operate your pump. Failure to do so could result in personal injury or damage to the pump.

This operation manual is designed to help you achieve the expected performance and longest life from the CNP pump.

SP Non-clogging self priming sewage pump is our latest developed product, and is suitable for the treatment project of municipal sewage and industrial sewage as well as stage treatment and concentrated treatment system of various sewages. It's known as "King of Self-priming Sewage Pump" and the most ideal new-generation sewage product.

1、 Application

- Non flammable and non-explosive liquid;
- Rain water and common sewage;
- Municipal drainage project ,construction site, drainage station of people's air defense system;
- Industrial sewage of light industry, paper mill, textile, food processing plant, chemical industry, electric utility, deep mines, etc;
- Sewage discharge in the residential area;
- Sewage and deposit of water purifying system;
- Tanning industry, sewage of slaughter house ,fish breeding in the river and pond;
- Wine and sugar industry;
- Discharge sewage of not strongly corrosive but seriously polluted.

2、 Model Explanation

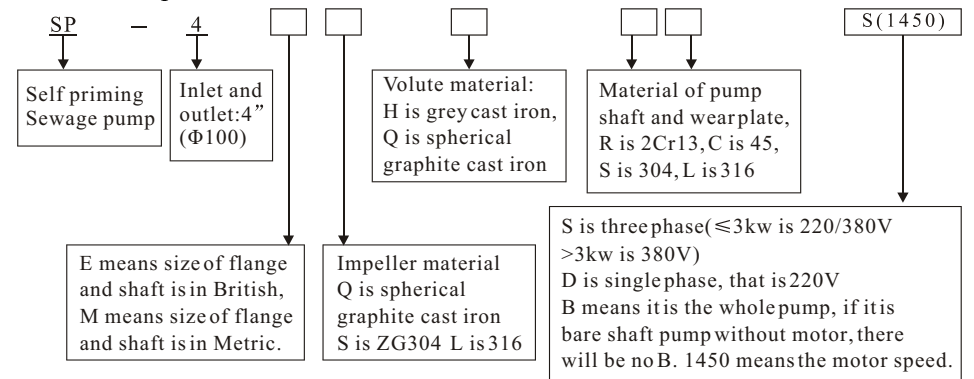

3. Operating condition

- Liquid temperature: 0°C-40°C, medium density $\leq 1.2 \times 10^3 \text{kg/m}^3$, pH5-9;
- Volume ratio of solids in the medium $\leq 2\%$;
- Diameter of maximum grain: SP-2 38mm SP-3 63mm; SP-4/SP-6 76mm
- Ambient temperature: $\leq 40^\circ\text{C}$
- Altitude: Max. 1,000m;
- Max. working pressure: see Performance Curve;
- Max. Suction head: see Performance Table

II、 STRUCTURE CHARACTERISTIC

1、 Features

- Stable performance, reliable operation;
- The motors clockwise rotation from drive; The pump shall be installed on the pedestal . axial suction and radial discharge;
- Back-pull-out construction :Convenient for maintenance and troubleshooting. Daily maintenance can be performed rapidly by common head tools, saving time and labor;
- Semi-open impeller structure and non-clogging design: Strong passing capacity.
- Convenient usage: The pump can be mounted high and dry at floor level. With only the suction line down in the liquid (the pump shall be filled with water for first start).
- Quick suction, high suction head, see performance table.

2、 Pump structure (Figures 1)

SP Non-clogging Self-priming Sewage Pump

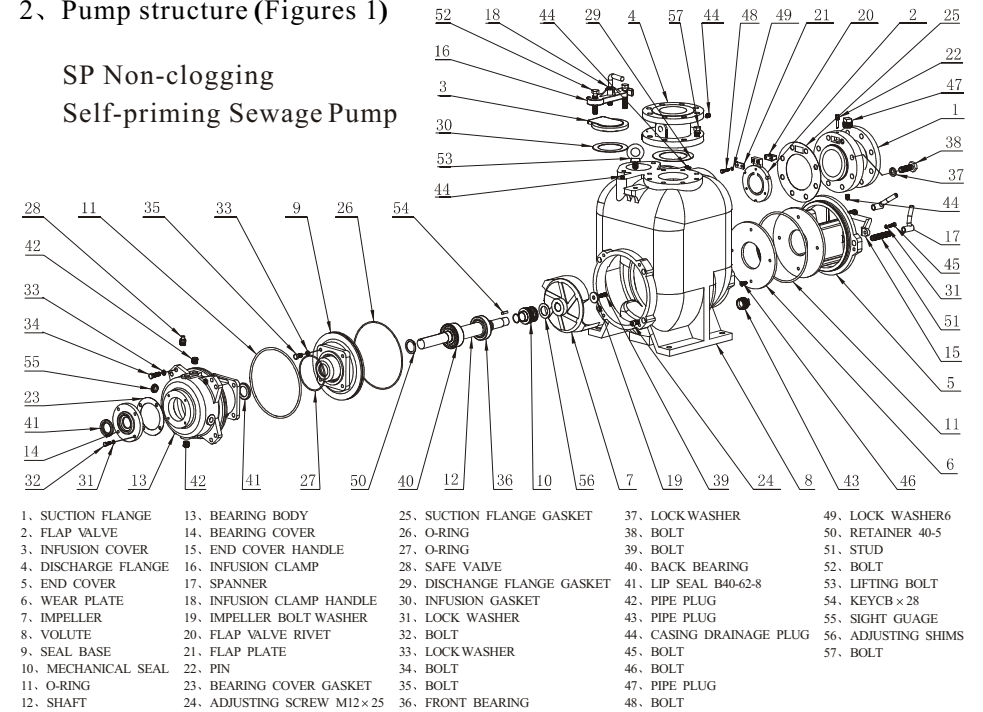

Figure 1 SP-080701

It is single-stage single suction cantilever pump. It is mainly composed of volute, impeller, wear plate, seal base, bearing body, etc;

The main wet part is made of cast iron parts;

Pump shaft is supported by two high precision rolling bearing, bearing cabinet and seal cabinet is lubricated by thin oil;

Shaft seal is single face mechanical seal, wearing part is WC/WC. O ring is made by NBR.

Pump and pipelines is connected by flanges which comply to GB/T standard.

III、 PERFORMANCE CURVE, PERFORMANCE PARAMETER, OPERATION RANGE

* Performance notes: (It is applicable to SP-2,3,4, 6 pump)

1) Performance is based on normal temperature clear water at sea level with minimum suction lift. Since pump installation is different, pump performance may be different due to such factors as flow rate, specific gravity, elevation, temperature. If the specific gravity of medium is bigger than 1kg/dm^3 , the power should be increased accordingly.

2) The RPM of the following table which marked by star(*), can be coupled by standard Y2 series and B3 series motor.

3) In order to reach other RPM listed in the following table, it can be done by the following way:

- driven by rubber belt of motor
- driven by variable speed motor
- driven by motor with variable speed device.



Pump speed and operating condition points must be in the performance range shown on the curve.

1. Performance curve

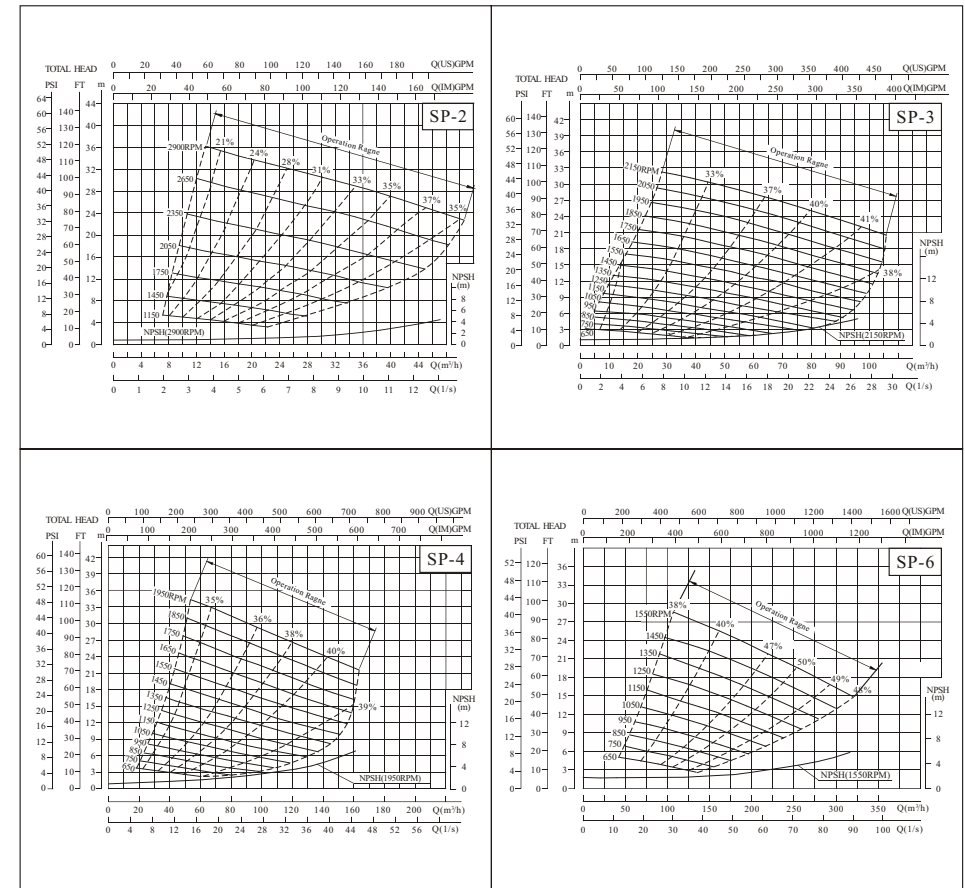

Figures 2: Pump performance curve

2. Performance Table

Model	RPM	Q		H m	Motor		Inlet& Outlet mm	Max. Solids mm	Max. Suction m
		m³/h	l/s		kW	HP			
SP-2	1150	15	4.2	4.0	0.75	1	50 (2')	38	5.5
	1450*	20	5.6	6.5	1.5	2			6.5
	1750	25	6.9	9.5	2.2	3			6.5
	2050	28	7.8	13.5	4.0	5.5			6.5
	2350	32	8.9	18.0	5.5	7.5			6.5
	2650	35	9.7	23.0	7.5	10			6.5
	2900*	40	11.1	27.0	9.2	12.5			6.5
Model	RPM	Q		H m	Motor		Inlet& Outlet mm	Max. Solids mm	Max. Suction m
		m³/h	l/s		kW	HP			
SP-3	650	25	6.9	2	0.75	1	80 (3')	63	1.5
	750*	30	8.3	3	1.5	2			1.8
	850	32.5	9.0	4	1.5	2			2.4
	950*	40	11.1	4.5	1.5	2			3.0
	1050	42.5	11.8	5.5	2.2	3			4.0
	1150	45	12.5	7	4.	5.5			4.9
	1250	50	13.9	8	4.	5.5			5.5
	1350	52.5	14.6	10	5.5	7.5			5.8
	1450*	55	15.3	11.5	5.5	7.5			6.4
	1550	60	16.7	12.5	7.5	10			6.4
	1650	65	18.1	14.5	11	15			6.7
	1750	70	19.4	16	11	15			6.7
	1850	72.5	20.1	18	15	20			7.6
	1950	75	20.8	20	15	20			7.6
2050	80	22.2	22.5	15	20	7.6			
2150	85	23.6	24.5	18.5	25	7.6			

2. Performance Table

Model	RPM	Q		H m	Motor		Inlet& Outlet mm	Max. Solids mm	Max. Suction m
		m³/h	l/s		kW	HP			
SP-4	650	40	11.1	3	1.5	2	100 (4')	76	1.5
	750*	45	12.5	4	1.5	2			2.4
	850	53	14.7	5	2.2	3			4.9
	950*	60	16.7	6	3	4			5.8
	1050	65	18.1	7.5	4	5.5			6.7
	1150	72	20.0	9	5.5	7.5			7.3
	1250	80	22.2	10.5	7.5	10			7.6
	1350	85	23.6	12.5	11	15			7.6
	1450*	100	27.8	13.5	11	15			7.6
	1550	110	30.6	15.5	15	20			7.6
	1650	115	31.9	18	15	20			7.6
	1750	120	33.3	20	18.5	25			7.6
1850	130	36.1	22.5	22	30	7.6			
1950	135	37.5	25	30	40	7.6			
Model	RPM	Q		H m	Motor		Inlet& Outlet mm	Max. Solids mm	Max. Suction m
		m³/h	l/s		kW	HP			
SP-6	650	100	27.8	3.5	2.2	3	150 (6')	76	2.4
	750*	125	34.7	4.5	4	5.5			2.7
	850	150	41.7	5.5	5.5	7.5			3.6
	950*	160	44.4	7.5	7.5	10			4.2
	1050	180	50.0	9.0	11	15			5.5
	1150	200	55.6	10.0	15	20			6.4
	1250	220	61.1	12.5	18.5	25			6.4
	1350	230	63.9	15	22	30			6.7
	1450*	250	69.4	17	30	40			7.0
	1550	280	77.8	18	30	40			7.6

3. Operating Range

Model	RPM	Q (m ³ /h)	10	12.5	15	17.5	20	25	30	35	40	45
SP-2	1150	H (m)	5.1	4.7	4.0	3.8	3.5					
	1450*		8.4	8.1	7.6	7.3	6.5	5.8				
	1750		12.6	12.2	11.8	11.3	10.8	9.5	8.5			
	2050		17.9	17.2	16.7	16.1	15.5	14.5	13.2	11.6		
	2350			23.2	22.5	21.8	21.2	19.9	18.6	17.2	15.3	
	2650			30.1	29.2	28.4	27.6	26.2	24.8	23.0	21.6	19.4
	2900*				35.6	34.5	33.7	32.1	30.4	29.0	27.0	25.3
Model	RPM	Q (m ³ /h)	10	20	30	40	50	60	70	80	90	100
SP-3	650	H (m)	2.9	2.5	2.0							
	750*		3.9	3.5	3.0	2.3						
	850		5.2	4.7	3.9	3.4						
	950*		6.4	6.0	5.2	4.5	3.8					
	1050		7.9	7.4	6.7	5.9	5.0	4.3				
	1150		9.7	9.0	8.3	7.4	6.5	5.6				
	1250		11.3	10.7	10.0	9.1	8.0	7.1	6.2			
	1350			12.6	11.9	11.0	10.0	9.0	7.7			
	1450*			14.7	14.0	12.9	12.0	10.8	9.6	8.3		
	1550			16.8	16.1	15.1	14.0	12.5	11.7	10.4	9.1	
	1650			19.3	18.5	17.4	16.2	15.0	13.6	12.3	11.1	
	1750				20.9	19.7	18.7	17.5	16.0	14.5	13.2	11.8
	1850					23.5	22.5	21.2	20.0	18.4	16.9	15.3
1950				26.2	25.3	24.1	22.7	21.0	19.6	17.9	16.4	
2050				29.0	28.0	26.8	25.3	24.0	22.5	20.5	18.9	
2150				32.1	31.0	29.7	28.2	26.8	25.1	23.4	21.7	

3. Operating Range

Model	RPM	Q (m ³ /h)	20	32	48	64	80	96	112	128	144	160	
SP-4	650	H (m)	3.8	3.3	2.6								
	750*			4.5	3.7	3.0							
	850			6.0	5.3	4.5	3.5						
	950*			7.5	6.5	5.7	5.0						
	1050			9.7	8.7	7.8	6.8	5.9					
	1150			11.9	10.8	9.9	8.8	7.6					
	1250			14.2	13.2	12.0	10.8	9.5	8.4				
	1350			16.7	15.7	14.3	13.1	11.8	10.5				
	1450*					18.0	16.5	15.5	14.0	12.5	11.5		
	1550					20.9	19.8	18.3	16.9	15.4	13.8	12.6	
	1650					24.3	22.9	21.1	19.8	18.1	16.3	15.0	
1750				27.6	26.2	24.4	22.9	21.3	19.3	17.5	16.2		
1850				31.0	29.8	27.7	26.1	24.4	22.5	20.5	18.7		
1950				34.5	33.4	31.5	29.4	27.7	25.7	23.5	21.7		
Model	RPM	Q (m ³ /h)	50	80	120	150	180	210	240	270	300		
SP-6	650	H (m)	5.0	4.2	3.1								
	750*			6.0	4.7	3.6							
	850			8.0	7.0	5.5							
	950*			11.0	9.5	7.5	6.8						
	1050			13.0	11.0	10.0	9.0	7.5					
	1150			16.0	14.0	12.8	11.2	10.0	8.0				
	1250				17.0	15.5	14	12.7	10.5				
	1350					20.5	19.0	17.5	15.5	14.0	12.0		
	1450*					24	22.0	21	19.0	17.0	15.0	13.0	
	1550					28	26.0	24.5	22.7	20.5	18.5	16.5	

IV. OUTLINE DRAWING

1、Pump Dimensions

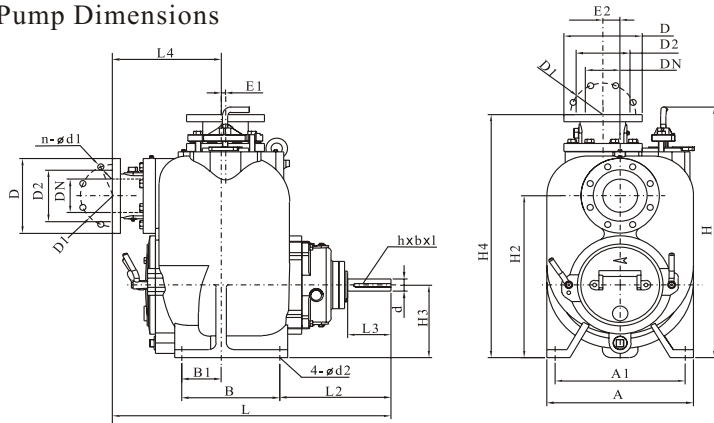

Figures 3 Pump Dimensions

Table3 Pump dimensions

Item		SP-2	SP-3	SP-4	SP-6	
Dimension of Inlet & Outlet Flange	PN	DIN(mm)	PN0.6MPa		PN1.0MPa	
		ANSI	Class150		Class150	
	DN	DIN(mm)	50	80	100	150
		ANSI	2"	3"	4"	6"
	D	DIN(mm)	140	190	220	285
		ANSI	6"	7.5"	9"	11"
	D1	DIN(mm)	110	150	180	240
		ANSI	4.75"	6"	7.5"	9.5"
	D2	DIN(mm)	90	128	158	214
		ANSI	3.6"	5"	6.2"	8.34"
n-φd1	DIN(mm)	4-φ14	4-φ19	8-φ19	8-φ23	
	ANSI	4-φ3/4"	4-φ3/4"	8-φ3/4"	8-φ7/8"	
Installation Dimension	H2(mm)	318	431.8	495.3	574.3	
	A(mm)	308	377	428	580	
	A1(mm)	281	328	373	527	
	B(mm)	163.2	228.6	279.4	279.4	
	B1(mm)	54	76.2	110	77.8	
	L2(mm)	274.8	285	326	294	
	d2(mm)	φ14	φ18	φ18	φ18	
	H3(mm)	151.5	190.5	222.2	257.2	
	L3(mm)	104	102	127	127	
	d	DIN(mm)	φ38			
	ANSI	φ1.5"				
h×b×l	DIN(mm)	10×5×95	10×5×80	10×5×90	10×5×90	
	ANSI	.38"×.19"×3.74"	.38"×.19"×3"	.38"×.19"×3.5"		
Profile Dimension	H(mm)	552	697.5	760	875	
	H4(mm)	502	652	735	887.7	
	L(mm)	615	712.2	813.5	906.6	
	L4(mm)	233	277	318	411	
	E1(mm)	27.5	15	13	0	
	E2(mm)	70	50	50	50	
Wt. (kg/lbs)		99/218	190/419	275/606	438/966	

2、Profile & Installation Dimension of Pump Unit With Motor

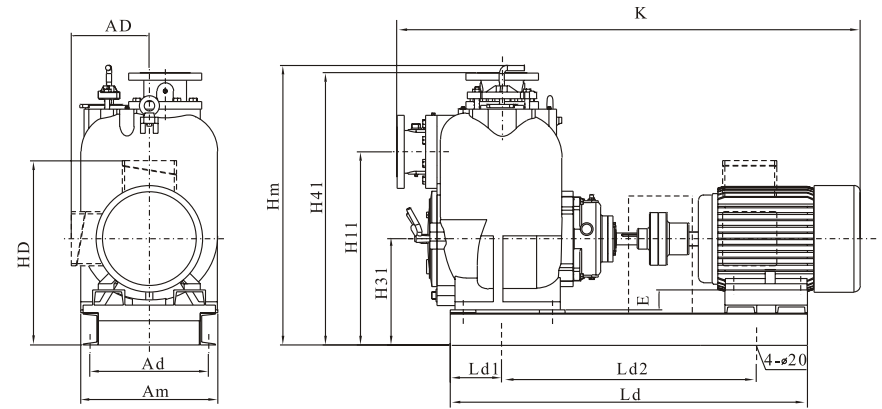

Figures 4 Installation Dimension of Pump Unit With Motor

Table4 Installation Dimension of Pump Unit With Motor

Model	Speed RPM	Motor Frame	Installation Dimension					Profile Dimension							
			Ad	Ld2	H11	H31	H41	K	Am	Hm	HD	AD	E	Ld	Ld1
SP-2	1450	Y2-90L-4 4 Poles	306	695	428	261.5	612	982	341	662	422	155	61.5	864	100
	2900	Y2-132-2 2 Poles						1107			575	210	19.5		
SP-3	750	Y2-112M-8 8 Poles	330	614	542	300.5	761	1134	380	785	489	190	78.5	861	
	950	Y2-100L-6 6 Poles						1119			471	180	90.5	854	
	1450	Y2-132S-4 4 Poles		660				1204			514	210	58.5	900	
SP-4	750	Y2-112M-8 8 Poles	370	702	606.3	332.2	843	1236	430	871	520	190	110.2	963	
	950	Y2-132S-6 6 Poles						1306			545	210	90.2	1002	
	1450	Y2-160M-4 4 Poles		821				1451			592	255	62.2	1121	
SP-6	750	Y2-160M-8 8 Poles	510	784	710	393	1022	1544	590	996	653	255	97.2	1084	
	950	Y2-160M-6 6 Poles						1544			653	255	97.2	1084	
	1450	Y2-200L-4 4 Poles		905				1705			738	305	57.2	1205	

*: 1)The base is welded by profiled bar; 2)Mounting Type:IMB3

V. INSTALLATION

1. Preinstall Inspection

The pump assembly was inspected and tested before shipment from the factory. Before installation, inspect the pump for damage which may have occurred during shipment. Check as follows:

Inspect the pump for cracks, dents, damaged threads, and other obvious damage,

Check for and tighten loose attaching hardware. Since gaskets tend to shrink after drying, check for loose hardware at mating surfaces.

Carefully read all tags, decals, and markings on the pump assembly, and perform all duties indicated.

Check levels and lubricate as necessary.

If the pump and engine have been stored for more than 12 months, some of the components or lubricants may have exceeded their maximum shelf life. These must be inspected or replaced to ensure maximum pump service.

2. Positioning Pump(Figure 5)

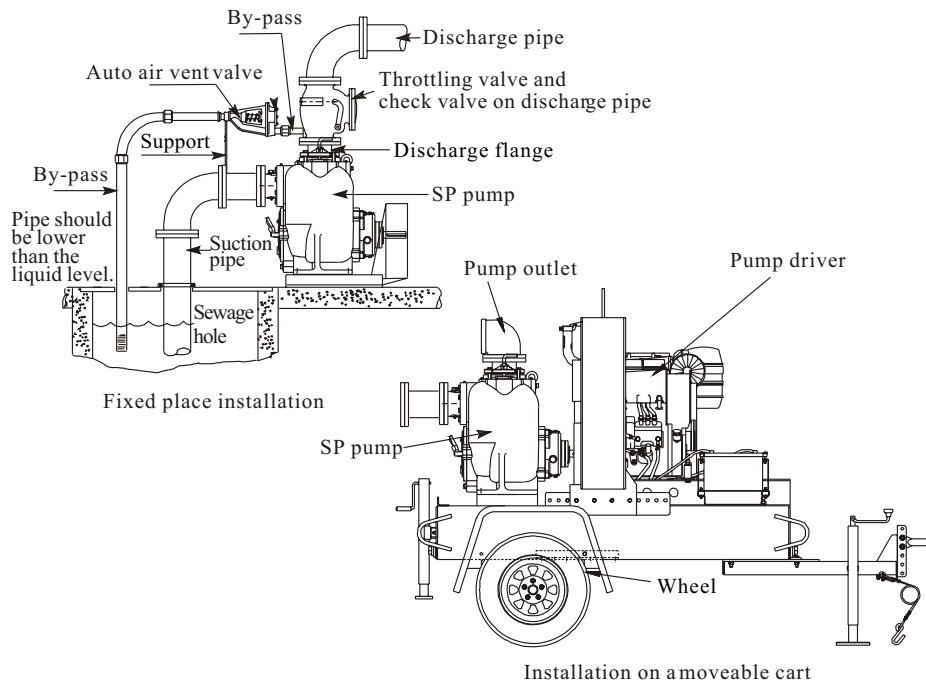

Figure 5 (Pump installation sketch figure)

Locate the pump in an accessible place as close as practical to the liquid being pumped. Level mounting is essential for proper operation.

The pump may have to be supported or shimmed to provide for level operation or to eliminate vibration, or shimmed by rubber cushion when necessary.

If the pump has been mounted on a moveable base, make certain the base is stationary by setting the brake and blocking the wheels before attempting to operate the pump.

Do not position the pump and engine more than 15° off horizontal for continuous operation.

If installed in a flooded suction application where the liquid is supplied to the pump under pressure. Since the pressure supplied to the pump is critical to performance and safety, be sure to limit the incoming pressure to 50% of the maximum permissible operating pressure as shown on the pump performance curve.

Clearance

When positioning the pump, allow a minimum clearance of 500 mm in front of the end cover to permit removal of the cover and easy access to the pump interior.

Suction And Discharge Piping

Pump performance is adversely effected by increased suction lift, discharge elevation, and friction losses. See the performance curve and notes on Page E-1 to be sure your overall application allows pump to operate within the safe operation range.

Materials

Either pipe or hose maybe used for suction and discharge lines; however, the materials must be compatible with the liquid being pumped. If hose is used in suction lines, it must be the rigid-wall, reinforced type to prevent collapse under suction. Using piping couplings in suction lines is not recommended.

3. Line Configuration

Keep suction and discharge lines as straight as possible to minimize friction losses. make minimum use of elbows and fittings, which substantially increase friction loss. If elbows are necessary, use the long-radius type to minimize friction loss.

Connections to Pump

Before tightening a connecting flange, align it exactly with the pump port. Never pull a pipe line into place by tightening the flange bolts and/or couplings.

Lines near the pump must be independently supported to avoid strain on the pump which could cause excessive vibration, decreased bearing life, and increased shaft and seal wear. If hose-type lines are used, they should have adequate support to secure them when filled with liquid and under pressure.

Gauges

Most pumps are drilled and tapped for installing discharge pressure and vacuum suction gauges. If these gauges are desired for pumps that are not tapped, drill and tap the suction and discharge lines not less than 18 inches (460 mm) from the suction

and discharge ports and install the lines. Installation closer to the pump may result in erratic readings.

Suction Lines

To avoid air pockets which could affect pump priming, the suction line must be as short and direct as possible. When operation involves a suction lift, the line must always slope upward to the pump from the source of the liquid being pumped; if the line slopes down to the pump at any point along the suction run, air pockets will be created.

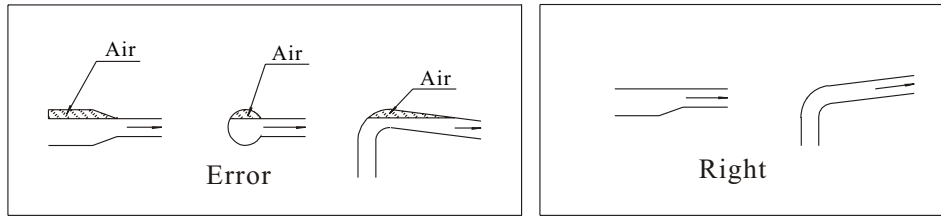

Figures 6

Suction lines should be the same size as the pump inlet. If reducers are used in suction lines, they should be the eccentric type, and should be installed with the flat part of the reducers uppermost to avoid creating air pockets. Valves are not normally used in suction lines, but if a valve is used, install it with the stem horizontal to avoid air pockets.

Strainers

If a strainer is furnished with the pump, be certain to use it; any spherical solids which pass through a strainer furnished with the pump will also pass through the pump itself.

Sealing

Since even a slight leak will affect priming, head, and capacity, especially when operating with a high suction lift, all connections in the suction line should be sealed with pipe dope to ensure an airtight seal. Follow the sealant manufacturer's recommendations when selecting and applying the pipe dope. The pipe dope should be compatible with the liquid being pumped.

Suction Lines In Sumps

If a single suction line is installed in a sump, it should be positioned away from the wall of the sump at a distance equal to 1.5 times the diameter of the suction line.

If two suction lines are installed in a single sump, the flow paths may interact, reducing the efficiency of one or both pumps. To avoid this, position the suction inlets so that they are separated by a distance equal to at least 3 times the diameter of the suction pipe.

Suction Line Positioning

The depth of submergence of the suction line is critical to efficient pump operation. (Figure 7) shows recommended minimum submergence vs. flow rate.

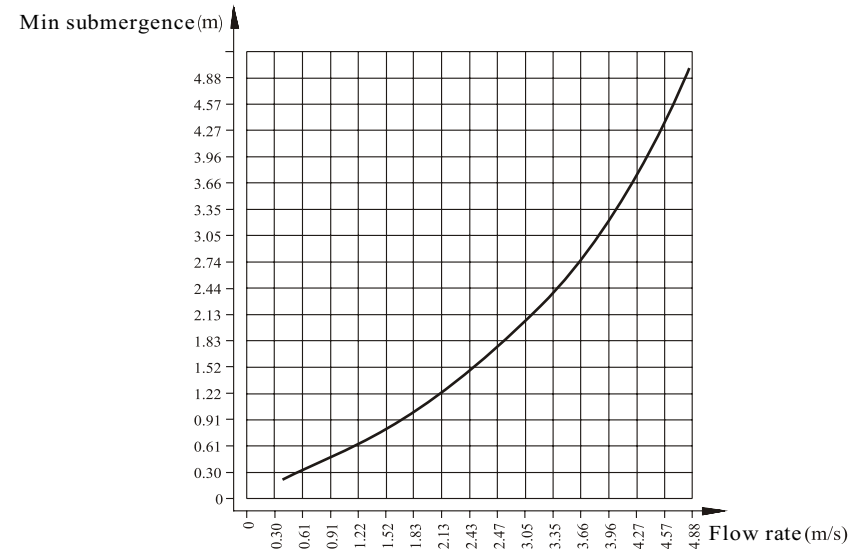

Figures 7 Flow rate and submergence

Discharge Lines

Valves

A check valve in the discharge line is normally recommended, but it is not necessary in low discharge head applications.

If a throttling valve is desired in the discharge line, use a valve as large as the largest pipe to minimize friction losses. Never install a throttling valve in a suction line.

With high discharge heads, it is recommended that a throttling valve and a system check valve be installed in the discharge line to protect the pump from excessive shock pressure and reverse rotation when it is stopped.

CAUTION

If the application involves a high discharge head, gradually close the discharge throttling valve before stopping the pump.

Bypass Lines

Self-priming pumps are not air compressors. During the priming cycle, air from the suction line must be vented to atmosphere on the discharge side. If the discharge line is open, this air will be vented through the discharge. However, if a check valve has been installed in the discharge line, the discharge side of the pump must be opened to atmospheric pressure through a bypass line installed between the pump discharge and the check valve. A self-priming centrifugal pump will not prime if there is sufficient static liquid head to hold the discharge check valve closed.

It is also recommended that pipe unions be installed at each 90° elbow in a bypass line to ease disassembly and maintenance.

The bypass line should be sized so that it does not affect pump discharge capacity; however, the bypass line should be at least 25 mm in diameter to minimize the chance of plugging.

In low discharge head applications less than 10 m, it is recommended that the bypass line be run back to the wet well, and located under 150 mm below the water level or cut-off point of the low level pump. In some installations, this bypass outline may be terminated with a six-to eight foot length (2 to 2,5 m) of 30 mm I.D. smooth-bore hose; air and liquid vented during the priming process will then agitate the hose and break up any solids, grease, or other substances likely to cause clogging.

In high discharge head applications (more than 10 meters), an excessive amount of liquid may be bypassed and forced back to the wet well under the full working pressure of the pump; this will reduce overall pumping efficiency. Therefore, it is recommended that a Automatic Air Release Valve be installed in the bypass line.

Automatic Air Release Valve: When properly installed and correctly adjusted to the specific hydraulic operating conditions of the application, the Automatic Air Release Valve will permit air to escape through the bypass line, and then close automatically when the pump is fully primed and pumping at full capacity.

About installation and working principle of Automatic Air Release Valve, related user manuals of these products can be referred.

Horizontal adjustment

The alignment of pump shaft and motor shaft is very important to ensure pump work well without failure. Put some washer on the footer of pump and motor.

4. Coupled Drives



WARNING!

When checking alignment, disconnect the power source to ensure that the pump will remain inoperative.

Adjusting the alignment in one direction may alter the alignment in another direction. Check each procedure after altering alignment.

When using couplings, the axis of the power source must be aligned to the axis of the pump shaft in both the horizontal and vertical planes. Most couplings require a specific gap or clearance between the driving and the driven shafts.

Align spider insert type couplings by using calipers to measure the dimensions on the circumference of the outer ends of the coupling hub every 90 degrees. The coupling is in alignment when the hub ends are the same distance apart at all points (See Figure 8).

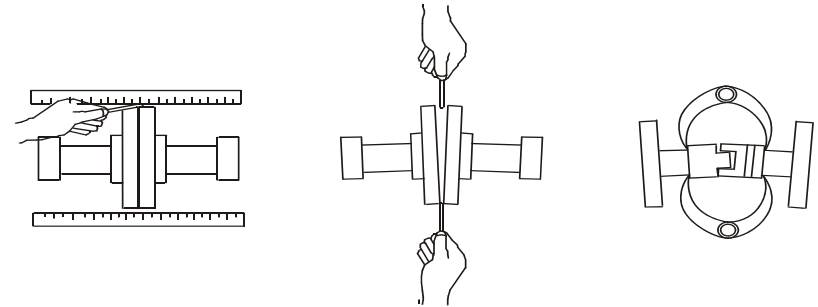

Figures 8

Align non-spider type couplings by using a feeler gauge or taper gauge between the coupling halves every 90 degrees. The coupling is in alignment when the hubs are the same distance apart at all points.

Check parallel adjustment by laying a straightedge across both coupling rims at the top, bottom, and side. When the straightedge rests evenly on both halves of the coupling, the coupling is in horizontal parallel alignment. If the coupling is misaligned, use a feeler gauge between the coupling and the straightedge to measure the amount of misalignment.

V-Belt Drives

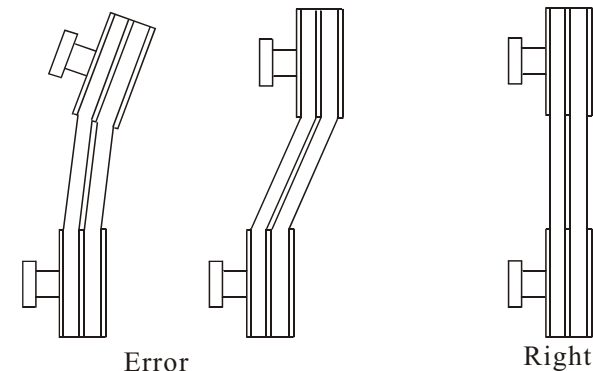

Figures 9

When using V-belt drives, the power source and the pump must be parallel. Use a straightedge along the sides of the pulleys to ensure that the pulleys are properly aligned (see Figure 11).

In drive systems using two or more belts, make certain that the belts are a matched set; unmatched sets will cause accelerated belt wear.

Select pulleys that will match the proper speed ratio; over speeding the pump may damage both pump and power source.

⚠ DANGER!

Do not operate the pump without the guard in place over the rotating parts. exposed rotating parts can catch clothing, fingers, or tools, causing severe injury to personnel.

5、Electrical Connections

If the pump is driven by an electric motor, check that the electrical service available matches the motor requirements stamped on the motor nameplate before connecting a motor to the incoming power. Check that the motor speed meets pump specifications.

If rotation is incorrect on a three-phase motor, have a qualified electrician interchange any two of the three phase wires to change direction. If rotation is incorrect on a single-phase motor, consult the literature supplied with the motor for specific instructions.

⚠ WARNING!

The electrical power used to operate the pump is high enough to cause injury or death. Obtain the services of a qualified electrician to make all electrical connections.

VI、START-UP

⚠ WARNING!

This pump is designed to handle sewage containing large entrained solids. Do not attempt to pump volatile, corrosive, or flammable liquids which may damage the pump or endanger personnel as a result of pump failure.

⚠ CAUTION

Choose the suitable motor for the pump according to the application. Never increase the operating speed which will cost more input power of pump.

1、Before The Start Prepares

Install the pump and piping as described in INSTALLATION. Make sure that the piping connections are tight, and that the pump is securely mounted. Check that the pump is properly lubricated.

This pump is self-priming, but the pump should never be operated unless there is liquid in the pump volute.

⚠ CAUTION

Never operate this pump unless there is liquid in the pump volute. The pump will not prime when dry. Extended operation of a dry pump will destroy the seal assembly. Add liquid to the pump volute when:

The pump is being put into service for the first time.
The pump has not been used for a considerable length of time.
The liquid in the pump volute has evaporated.

Add liquid to the pump volute:

Shut off all the outlet valves, open the infusion cover, plug, add clean water in it, then fit back the infusion cover and plug.

⚠ WARNING!

After filling the pump volute, reinstall and tighten the fill plug. Do not attempt to operate the pump unless all connecting piping is securely installed. Otherwise, liquid in the pump forced out under pressure could cause injury to personnel.

2、Starting

Starting procedures will vary slightly depending on the pump application, type of priming device, and type of drive. Consult the operations manual furnished with the power source.

If the pump is driven by an electric motor, consult the operating manual furnished with the motor before attempting to start the motor.

Lines Without a Bypass

Partially open outlet valve before start the pump, so the air can be vented out by outlet pipe and ensure the pump run without full load. Priming is indicated by a positive reading on the discharge pressure gauge or by a quieter operation. The pump may not prime immediately because the suction line must first fill with liquid. If the pump fails to prime within five minutes, stop it and check the suction line for leaks.

Lines With a Bypass

Bypass line is open

In low discharge head applications less than 10 m., If the bypass line is open, air from the suction line will be discharged through the bypass line back to the wet well during the priming cycle. Liquid will then continue to circulate through the bypass line while the pump is in operation.

Bypass line with manual valve

Open manual valve on bypass before starting, when self priming, air will go to sewage hole through bypass and manual valve. After self priming, close manual valve by hand. Reopen manual valve when self priming next time.

Bypass line with automatic air release valve: the valve will automatically open to allow the pump to prime, and automatically close after priming is complete.

After the pump has been primed, partially close the discharge line throttling valve in order to fill the line slowly and guard against excessive shock pressure which could damage pipe ends, gaskets, sprinkler heads, and any other fixtures connected to the line. When the discharge line is completely filled, adjust the throttling valve to the required flow rate.

⚠ WARNING!

Do not run pump exceed the range as the performance curve indicated.

Rotation

The motors clockwise rotation from drive.

If rotation is incorrect on a three-phase motor, have a qualified electrician interchange any two of the three phase wires to change direction. If rotation is incorrect on a single-phase motor, consult the literature supplied with the motor for specific instructions.

Alignment

The alignment of the pump and the engine is critical for trouble-free mechanical operation.

It is very important to check the pump shaft and motor shaft to ensure they are aligning. If the pump is installed before ex work, pump shaft should be aligned with motor shaft. But, shafts will move when shipment. So, pump must be checked before starting. Check whether coupling and footer screws are tighten.

After pump running for 3 to 4 hours, do a final check, if it works well, we think the installation is successful. When commissioning, check bearing body. The max temperature near bearing body end should not exceed 70°C.

3、 Operation

No leakage should be visible at pump mating surfaces, or at pump connections or fittings. Keep all line connections and fittings tight to maintain maximum pump efficiency.

Liquid Temperature And Overheating

The maximum liquid temperature for this pump is 70°C. Do not apply it at a higher operating temperature.

Overheating can occur if operated with the valves in the suction or discharge lines closed. Operating against closed valves could bring the liquid to a boil, build pressure, and cause the pump to rupture or explode. If overheating occurs, stop the pump and allow it to cool before servicing it. Refill the pump volute with cool liquid.

⚠ CAUTION

Allow an over-heated pump to completely cool before servicing. Do not open infusion cover, pressure gauge, pipes before cool. Vent water in volute by opening the water vent screw.

Strainer Check

If a suction strainer has been shipped with the pump or installed by the user, check the strainer regularly, and clean it as necessary. The strainer should also be checked if pump flow rate begins to drop. If a vacuum suction gauge has been installed, monitor and record the readings regularly to detect strainer blockage.

Never introduce air or steam pressure into the pump volute or piping to remove a blockage. This could result in personal injury or damage to the equipment. If back flushing is absolutely necessary, liquid pressure must be limited to 50% of the maximum permissible operating pressure shown on the pump performance curve.

Bearing Temperature Check

Bearings normally run at higher than ambient temperatures because of heat generated by friction. Bearings can operate safely to at least 80°C.

Checking bearing temperatures by hand is inaccurate. Bearing temperatures can be measured accurately by placing a contact-type thermometer against the housing. Record this temperature for future reference. If bearing temperature is risen quickly, it indicates there may be something wrong with the bearing. Check the density of bearing lubricate and the lubricate level. The overheat of the bearing may also be caused by misalignment shaft or extreme vibration.

When the pump just started, the bearing temperatures will rise. When running stable, bearing temperature will go to normal

Pump Running Control

Do not start pump too frequently.

Run it at the real working condition and at chosen rotating speed and in allowed range. Do not speed up pump randomly or increase pump flow when running, or it will cost more input power of pump.

When running, note if there is noise. If find out something wrong, stop it and check it.

4、 Stopping

Never halt the flow of liquid suddenly. If the liquid being pumped is stopped abruptly, damaging shock waves can be transmitted to the pump and piping system. Close all connecting valves slowly.

On engine driven pumps, reduce the throttle speed slowly and allow the engine to idle briefly before stopping.

Cold Weather Preservation

In below freezing conditions, drain the pump to prevent damage from freezing. Also, clean out any solids by flushing with a hose. Operate the pump for approximately one minute; this will remove any remaining liquid that could freeze the pump rotating parts. If the pump will be idle for more than a few hours, or if it has been pumping liquids containing a large amount of solids, drain the pump, and flush it thoroughly with clean water. To prevent large solids from clogging the drain port and preventing the pump from completely draining, insert a rod or stiff wire in the drain port, and agitate the liquid during the draining process. Clean out any remaining solids by flushing with a hose.

⚠ CAUTION

If the application involves a high discharge head, gradually close the discharge throttling valve before stopping the pump.

VII、 MAINTENANCE

Since pump applications are seldom identical, and pump wear is directly affected by such things as the abrasive qualities, pressure and temperature of the liquid being pumped, this section is intended only to provide general recommendations and practices for preventive maintenance. Regardless of the application however, following a routine preventive maintenance schedule will help assure trouble-free performance and long life from your pump

For new applications, a first inspection of wearing parts at 250 hours will give insight into the wear rate for your particular application. Subsequent inspections should be performed at the intervals shown on the chart below. Critical applications should be inspected more frequently.

Preventive Maintenance Schedule					
Item	Service Interval*				
	Daily	Weekly	Monthly	Semi-Annually	Annually
General Condition (Temperature, unusual Noises or Vibrations, Cracks, Leaks, Loose Hardware, Etc.)	I				
Pump Performance (Gauges, Speed, Flow)	I				
Bearing Lubrication		I			R
Seal Lubrication (And Packing Adjustment, If So Equipped)		I			R
V-Belts (If So Equipped)			I		
Air Release Valve Plunger Rod (If So Equipped)			I	C	
Front Impeller Clearance (Wear Plate)				I	
Rear Impeller Clearance (Seal Plate)				I	
Check Valve					I
Pump and Driver Alignment					I
Shaft Deflection					I
Bearings					I
Bearing Housing					I
Piping					I
Driver Lubrication . See operation manual					
Remark: I = Inspect, Clean, Adjust, Repair or Replace as Necessary C = Clean R = Replace * Service interval based on an intermittent duty cycle equal to approximately 4000 hours annually. Adjust schedule as required for lower or higher duty cycles or extreme operating conditions.					

VIII、 PUMP SERVICE, DISASSEMBLY AND REASSEMBLY

This pump requires little service due to its rugged, minimum-maintenance design. Normally, only need to clean the sewage. The service need not to disassemble the pipes or pump. Only remove the end cover with normal tool.

Sewage checking

Drain the volute through casing drainage plug, unscrew the bolt of end cover, pull out the end cover and wear plate with the handle. Then clean it.

Before attempting to open or service the pump:

--- Familiarize yourself with this manual.

--- Close the suction and discharge valves.

--- Vent the pump slowly and cautiously.

--- Drain the pump.

--- Switch off the engine ignition and remove the key to ensure that the pump will remain inoperative.

--- Allow the pump to completely cool if overheated.

--- Check the temperature before opening any covers, plates, or plugs.

(a) End cover removal

Loose the handle of end cover, pull the end cover and wear plate carefully with the handle. Inspect the wear plate and replace it if badly scored or worn.

Inspect the O ring on the seal face of the end cover, if worn out, replace with a new one.

Inspect the impeller and replace it if badly scored or worn. Before attempting to loosen the impeller, remove the seal cavity drain plug and drain the lubricant. This will prevent the oil from escaping as the impeller is removed. Clean and reinstall the drain plug.

Unscrew the impeller Bolt from the shaft. Use caution when removing the impeller; tension on the shaft seal spring will be released as the impeller is unscrewed. Inspect the impeller and replace if cracked or badly worn. Slide the impeller adjusting shims off the impeller shaft. Tie and tag the shims or measure and record their thickness for ease of reassembly.

Take apart the whole pump and service.

The following operation is based on assuming part is fully taken apart.

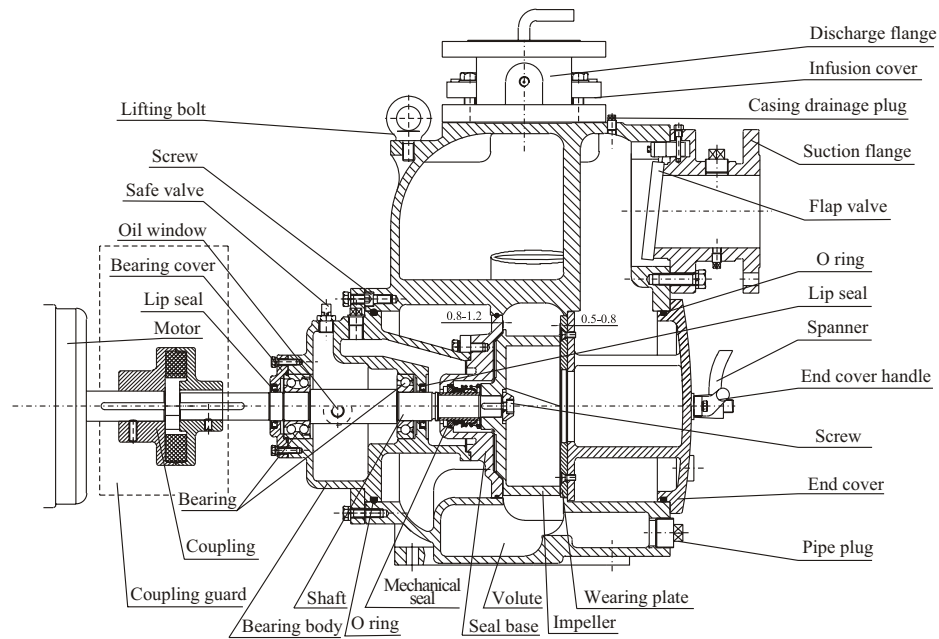

Figure 10 Pump service figure

(a) Flap Valve Removal

If the Flap Valve is to be serviced, remove the suction piping from the suction inlet flange;

Disengage the bolt and remove the suction flange, gasket and flap valve as an assembly.

(b) Separating Bearing Body and Drive Assembly From Engine

Further disassembly requires separating the pump end and drive assembly from the engine. Install a standard lifting eye in the tapped hole in the top of the pump volute. Be sure to screw the eye into the volute until fully engaged. Support the pump using a suitable hoist and the lifting eye. Disengage the hardware securing the drive flange to the engine bell housing, and remove the guards. Loose the footer screw, remove adjusting cushions, tag the adjusting cushions for case of reassembly. Separate the pump end and drive assembly from the engine by pulling the pump end straight away from the engine.

It is not necessary to remove the outer ring of the coupling from the engine fly wheel unless the coupling must be replaced. To remove the ring, disengage the hardware securing it to the flywheel.

As the assemblies separate, the flexible portion of the coupling assembly will remain on the shaft.

To remove the coupling from the shaft, unscrew the two head setscrews from the bushing. Screw one of the setscrews into the puller hole on the circumference of the bushing. As the coupling and bushing separate, remove the bushing, and slide the coupling off the shaft. Remove the shaft key. Remove any leveling shims used under the volute mounting feet. Tie and tag the shims for ease of reassembly. Move the pump end to a clean, well equipped shop area for further disassembly.

Loose the connecting screws between bearing body and volute, unscrew the adjusting bolts by turns, pull the bearing body from volute slowly. Check the O ring of the seal face of bearing body. Replace it if worn.

(c) Loosening Impeller and Impeller Removal

Before attempting to loosen the impeller, remove the seal cavity drain plug and drain the lubricant. This will prevent the oil from escaping as the impeller is removed. Clean and reinstall the drain plug. Remove impeller from the shaft with tool, use caution when removing the impeller; tension on the shaft seal spring will be released as the impeller is unscrewed. Inspect the impeller and replace if cracked or badly worn. Slide the impeller adjusting shims off the impeller shaft. Tie and tag the shims or measure and record their thickness for ease of reassembly. Shaft endplay should be between 0.8 mm to 1.2 mm. Add or remove adjusting shims as required to achieve the correct end-play.

(d) Cartridge Mechanical Seal Removal and Disassembly

Disassemble mechanical seal: From shaft, carefully remove adjusting shims, spring, cradle, shaft sleeve and seal ring. Inspect the seal components for wear, scoring, grooves, and other damage that might cause leakage. Clean and polish the shaft sleeve.

If a replacement seal is being used, remove it from the container and inspect the precision finished faces to ensure that they are free of any foreign matter.

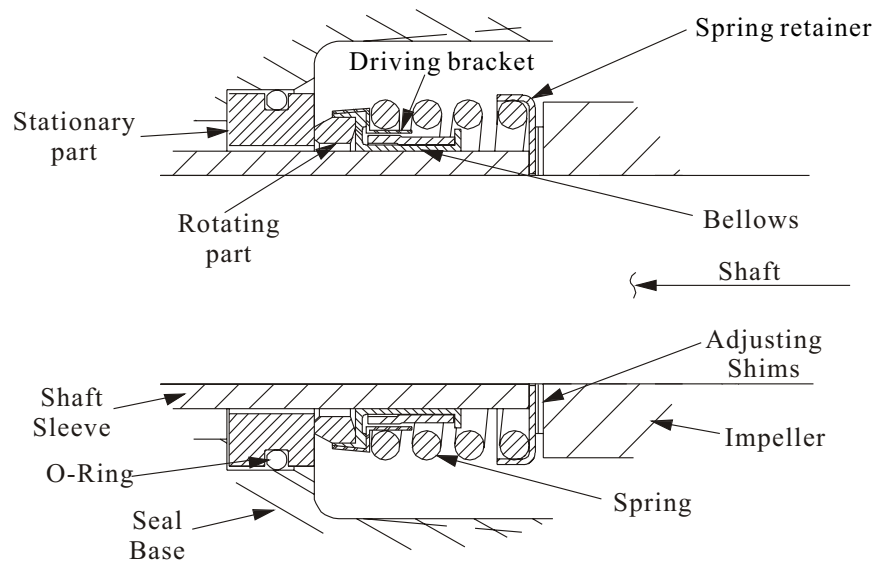

Figures 11

Reinstall mechanical seal: Clean the seal cavity and shaft with a cloth soaked in fresh cleaning solvent. Handle the seal parts with extreme care to prevent damage. Be careful not to contaminate precision finished faces.

To ease installation of the seal, lubricate the O-rings and bellows with water or a very small amount of oil, and apply a drop of light lubricating oil on the finished faces. Assemble the seal as follows, (see Figure 11).

This seal is not designed for operation at temperatures above 70°C Do not use at higher operating temperatures.

(e) Oil Seal Removal and Disassembly

Cavity Oil Seal Removal :Inspect the oil seal, replace with a new one if worn out, reinstall, press it to the bearing body by the hand, see figure 12 for the lip position.

(f) Shaft and Bearing Removal and Disassembly

When the pump is properly operated and maintained, the bearing housing should not require disassembly. Disassemble the shaft and bearings only when there is evidence of wear or damage.

CAUTION

Shaft and bearing disassembly in the field is not recommended. These operations should be performed only in a properly-equipped shop by qualified personnel.

Remove the Bearing Body drain plug and drain the lubricant. Clean and reinstall

the drain plug. Disengage the hardware and remove the Bearing Cover, gasket, outboard oil seal.

Press the oil seal from the Bearing Cover.

Place a block of wood against the impeller end of the shaft, and tap the shaft and assembled bearings from the intermediate. After removing the shaft and bearings, clean and inspect the bearings in place as follows.

Clean the bearings thoroughly in fresh cleaning solvent. Dry the bearings with filtered compressed air and coat with light oil.

CAUTION

Bearing should be kept clean, or it can't be run longer. Bearing can't be run without liquid, if so, the bearing balls and outer race will be damaged.

Rotate the bearings by hand to check for roughness or binding and inspect the bearing balls. If rotation is rough or the bearing balls are discolored, replace the bearings.

If bearing replacement is required, use a bearing puller to remove the inboard and outboard bearings from the shaft.

(g) Shaft and Bearing Reassembly and Installation (See figure 10)

Inspect the shaft for distortion, nicks or scratches, or for thread damage on the impeller end.

Slide the bearings onto the shaft, until they are fully seated.

Slide the shaft and assembled bearings into the bearing body bore until the inboard bearing is fully seated against the bore shoulder.

Apply a light coating of oil to the lip of the outboard oil seal, and press it into the bearing cover with the lip positioned as shown in Figure 10. Position the oil seal in the center of the bearing cover. Install the bearing cover gasket, and secure the bearing cover to the bearing body with the hardware. Be careful not to damage the lip of the oil seal on the shaft keyway.

Unscrew the safe valve on the top of bearing body, add the required thin lubricate, the amount is : Can see the oil level from the oil window.

(h) Re-assemble coupling

Install the shaft key in the shaft keyway. Position the flexible portion of the coupling assembly on the shaft.

Align the keyway in the bushing with the shaft key, and slide it onto the shaft to the dimension Rotate the flexible portion of the coupling until the tapped holes for the two setscrews align with those in the bushing, and install the setscrews.

(i) Fit Bearing Body In Volute

Fit O ring dismantled before on the flange of bearing body, brush thin oil on the O ring. Screw 4 adjusting screws on sunk-hole screw hole in volute. Let head of

adjusting screws be higher 2mm than surface of flange.

Fit bearing body in volute, surface of bearing body flange should be contacted flat with head surface of adjusting screws. Fix bearing body with bolts. Measure the distance from flange surface of volute end cover to end surface of vane of impeller. Then measure distance from wear plate to flange surface end cover. Make records.

(j) Refit End Cover, Adjust Clearance Between Impeller And Wear Plate

In order to keep the clearance from impeller to wear plate at 0.2 mm- 0.4mm. According to measure result, adjusting 4 adjusting screws: Loose connecting bolts for bearing body and pump, adjust 4 adjusting bolts equally. After adjusting, tighten connecting bolts.

Clean contact surface of volute to prevent from affecting seal of end cover. Refit O ring, paint thin oil on the surface of O ring. Paint thin oil on flange surface of end cover and volute. Press end cover and wear plate into volute. When pressing, keep axis of end cover and axis of volute combination at the same line, to prevent it from blocked. After fitting in place, press end cover tightly with screw wrench. Move coupling to move pump shaft, to make sure durable plate is not blocked with impeller.

(k) Fit Suction Inlet, Flap Valve

Fit repaired or new suction inlet on volute as the inverted order of "a ". Push flap valve from suction inlet to make sure it fit in place and move freely.

(l) Finish repairing and assembling

Lift pump unit with lifting machine and fit it. Adjust horizontal place of it by adjusting washers on the pump footer.

Make sure pump unit and motor fit in place and suitable.

Fit inlet pipe and outlet pipe and open all valves. Make sure all pipes connect tightly, support suitably.

Make sure lubricant has been added.

Open infusion cover of upper pump, injecting clean liquid in pump unit and close infusion cover.

Refer to "START-UP" to restart pump.

⚠ WARNING!

Do not lift the whole pump by lifting the lift screw, it need other supporting point to lift the whole pump.

IX、TROUBLESHOOTING

⚠ DANGER!

Before attempting to open or service the pump, switch off engine ignition and disconnect the positive battery cable to ensure that the pump will remain inoperative.

Allow the pump to completely cool if overheated.

TROUBLE	POSSIBLE CAUSE	PROBABLE REMEDY
PUMP FAILS TO PRIME	1. Not enough liquid in volute.	1. Add liquid to volute. .
	2. Suction strainer blocked or damaged.	2. Clean or replace strainer.
	3. Air leak in suction line.	3. Correct leak.
	4. Lining of suction hose collapsed.	4. Replace suction hose.
	5. Leaking or worn seal or pump gasket.	5. Check pump vacuum. Replace leaking or worn seal or gasket.
	6. Suction lift or discharge head too high.	6. Check piping installation and install bypass line if needed.
	7. Strainer clogged	7. Check strainer and clean if necessary.
PUMP STOPS OR FAILS TO DELIVER RATED FLOW OR PRESSURE	1. Air leak in suction line.	1. Check suction line.
	2. Lining of suction hose collapsed.	2. Replace suction hose.
	3. Leaking or worn seal or pump gasket.	3. Check pump vacuum. Replace leaking or worn seal or gasket.
	4. Strainer clogged.	4. Check strainer and clean if necessary.
	5. Suction intake not submerged at proper level or sump too small.	5. Check installation and correct submergence as needed.
	6. Impeller or other wearing parts worn or damaged.	6. Replace worn or damaged parts. Check that impeller is properly centered and rotates freely.
	7. Impeller clogged.	7. Free impeller of debris.
	8. Discharge head too high.	8. Install bypass line.
	9. Suction lift too high.	9. Measure lift w/vacuum gauge. Reduce lift and/or friction losses in suction line.
	10. Pump speed too slow.	10. Check engine output.
PUMP REQUIRES TOO MUCH POWER	1. Pump speed too high.	1. Check engine output.
	2. Discharge head too low.	2. Adjust discharge valve.
	3. Liquid solution too thick.	3. Dilute if possible.
	4. Bearing(s) frozen	4. Disassemble pump and check bearing(s).
PUMP CLOGS FREQUENTLY	1. Discharge flow too slow.	1. Open discharge valve fully to increase flow rate, and run engine at maximum governed speed.
	2. Suction check valve or foot valve clogged or binding.	2. Clean strainer.
	3. Liquid solution too thick.	3. Dilute if possible.
	4. Discharge line clogged or restricted; hose kinked	4. Check discharge lines; straighten hose.

EXCESSIVE NOISE	1.Cavitations in pump.	1.Reduce suction lift and/or friction losses in suction line.
	2.Pumping entrained air.	2.Locate and eliminate source of air bubble.
	3.Pump or drive not securely mounted.	3.Secure mounting hardware.
	4.Impeller clogged or damaged.	4.Clean out debris; replace damaged parts.
BEARINGS RUN TOO HOT	1.Bearing temperature is high, but within limits.	1.Check bearing temperature regularly to monitor any increase.
	2.Low or incorrect lubricant.	2.Check for proper type and level of lubricant.
	3.Suction and discharge lines not properly supported.	3.Check piping installation for proper support.
	4.Drive misaligned.	4.Align drive properly.

X. Important Notice

- 1.Customers will not be advised if this manual is updated.
- 2.Pump will be guaranteed for one year under normal operation with the correct model. Wearing part is not included.
- 3.Users shall be responsible for the damage if they disassemble the pumps by themselves in guaranteed period.